



D:81 mm

LKH SERIES

60W/80W/100W/150W/200W/250W



Remoto Control



Ahorro de energía



Solar Carga



Brillo Alto



Exterior Prueba Agua



Batería Alta Capacidad



Aluminio fundido Presión



Larga vida útil

SOLAR INTEGRADA FAROLA LAMPS

◆ Disipador de calor de una sola pieza fundido a presión ADC12, resistente al agua IP65

TAMAÑO DEL PRODUCTO

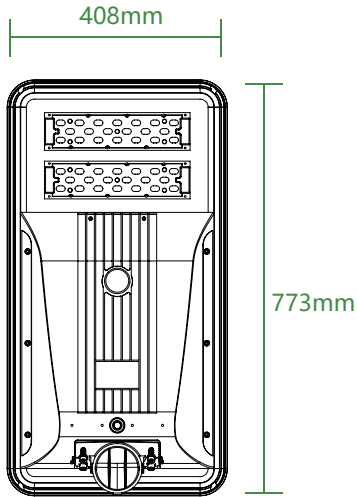

60W

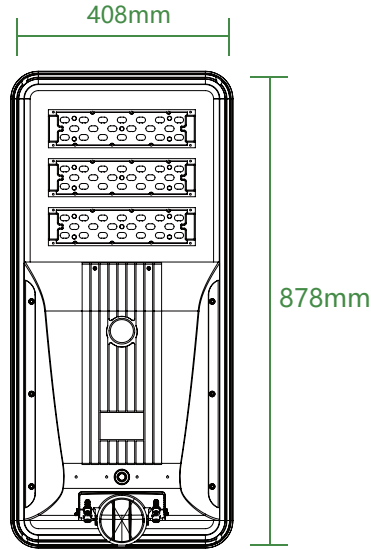

80W

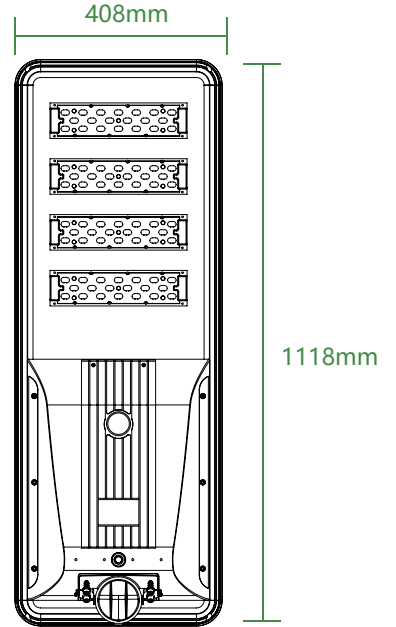

100W

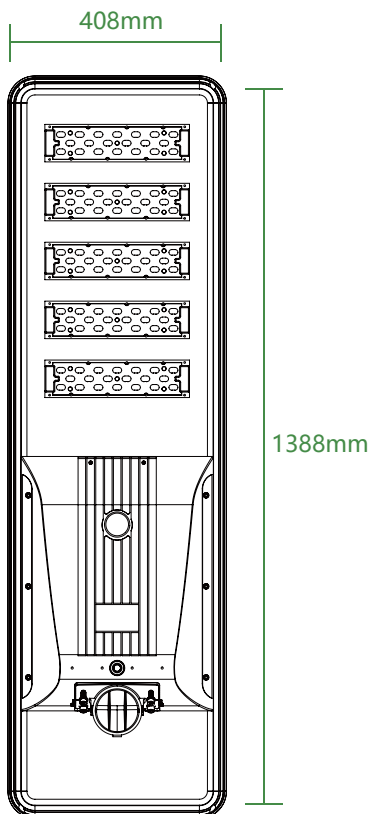

150W

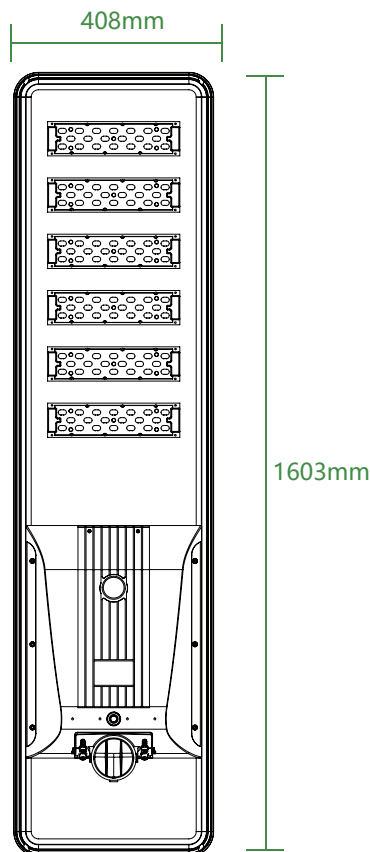

200W

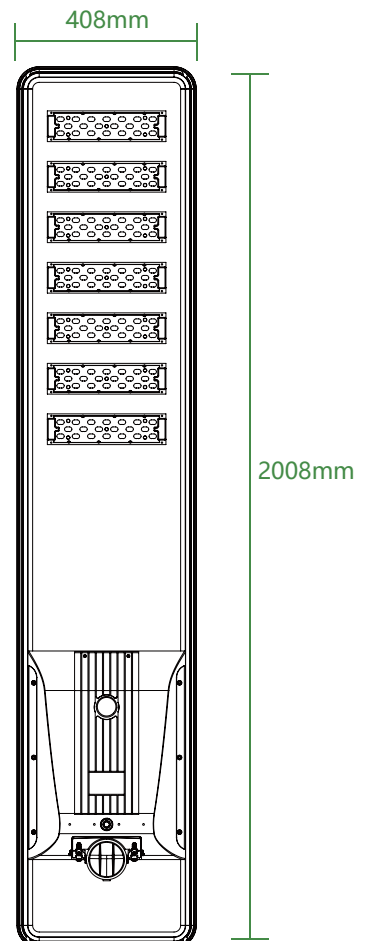

250W

CARACTERÍSTICA

- Fácil de instalar y mantener, con batería reemplazable fácilmente después de años.
- Batería de litio LifePO4 de larga duración que puede soportar entre 4 y 7 días de lluvia.
- Tiempos de ciclo de hasta 2500+, vida útil de 6 a 10 años.
- Alto nivel de lúmenes hasta 210 lm/w, chip LED Philips original.
- Panel solar de monocristalino con controlador MPPT para carga rápida de 4 a 6 horas.
- Toda la vida Mas > 50000 Horas.
- Lente óptica: alta transmitancia, luz suave, larga vida útil.



INTRODUCCIÓN DE FUNCIONES

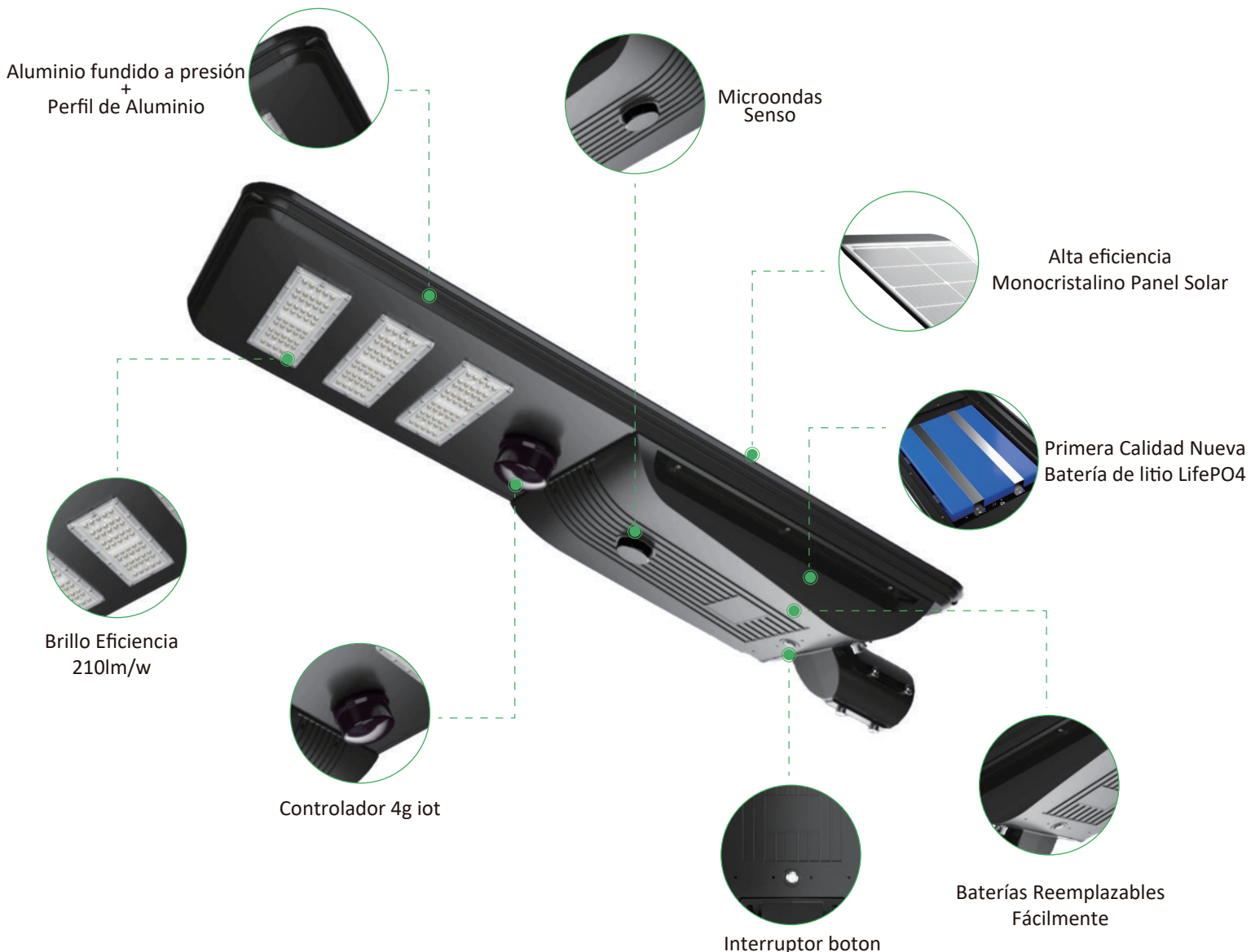

DATOS TÉCNICOS



LM-80



MODELO NUMERO	SED-LKH-60W	SED-LKH-80W	SED-LKH-100W	SED-LKH-150W	SED-LKH-200W	SED-LKH-250W
Fuerza	60W	80W	100W	150W	200W	250W
Solar Panel	18V/50W Mono	18V/60W Mono	18V/80W Mono	18V/105W Mono	18V/130W Mono	18V/150W Mono
Batería	Lithium LifePO4 battery 3.2V 72AH(231Wh)	Lithium LifePO4 battery 3.2V 100AH(320Wh)	Lithium LifePO4 battery 12.8V/30AH(384Wh)	Lithium LifePO4 battery 12.8V/45AH(576Wh)	Lithium LifePO4 battery 12.8V/60AH(768Wh)	Lithium LifePO4 battery 12.8V/75AH(960Wh)
LED	4 cores high efficiency smd 3030 96PCS	4 cores high efficiency smd 3030 144PCS	4 cores high efficiency smd 3030 192PCS	4 cores high efficiency smd 3030 240PCS	4 cores high efficiency smd 3030 288PCS	4 cores high efficiency smd 3030 336PCS
Tamaño del paquete	995*460*130mm	1100*460*130mm	1340*460*130mm	1610*460*130mm	1825*460*130mm	2230*460*130mm
Peso Neto	10.5KG	11.5KG	13.5KG	16KG	18.5KG	22KG
Eficacia	210LM/W					
Paneles Solares Eficiencia Conversión	23.8%					
Flujo Luminoso	6000LM	8000LM	12000LM	16000LM	20000LM	24000LM
Controlador	MPPT Controlador					
Ángulo de luz	75*155° / transmittance: >95%					
Gestión Sistemas Plataformas en la nube	Sistema de gestión de control de IoT (opcional)					
Método de iluminación	Control inteligente + Inducción de microondas + control de tiempo segmentado					
Tiempo de Descarga	4-7 días de lluvia					
Altura de instalación Recomendada	5-6m	6-8m	8-10m	10-12m	12-15m	15-18m

APLICACIONES

- Iluminación de carreteras
- Carreteras de parques industriales
- Todo tipo de caminos
- Calle urbana
- Area Rural
- Acera
- Zona de estacionamiento